

COMBINED PUMPS

On request, BERARMA pumps from the 01 PHP series can be set up for coupling:

- to pumps belonging to the same 01 PHP series;
- to pumps belonging to other BERARMA series;
- to the main others types of pumps available on the fluid power market.

The 01 PHP series pumps set up for coupling are marked by the letter "A" in the ordering code. In these pumps, the shaft and the rear pump cover are set up for coupling to the various available coupling units. Unscrew the screws marked (1) from the primary pump (screws will not be re-installed)

- Remove the pump cover marked as (1) from the primary pump (cover will not be re-installed)
- remove the ring marked (2) from the primary pump (ring will not be re-installed) (only for pump PHP 05)
- Mount the coupling unit, paying attention to the seals (Note: primary pump drainage fluid will fill up the coupling bell-housing)
- Mount the secondary pump

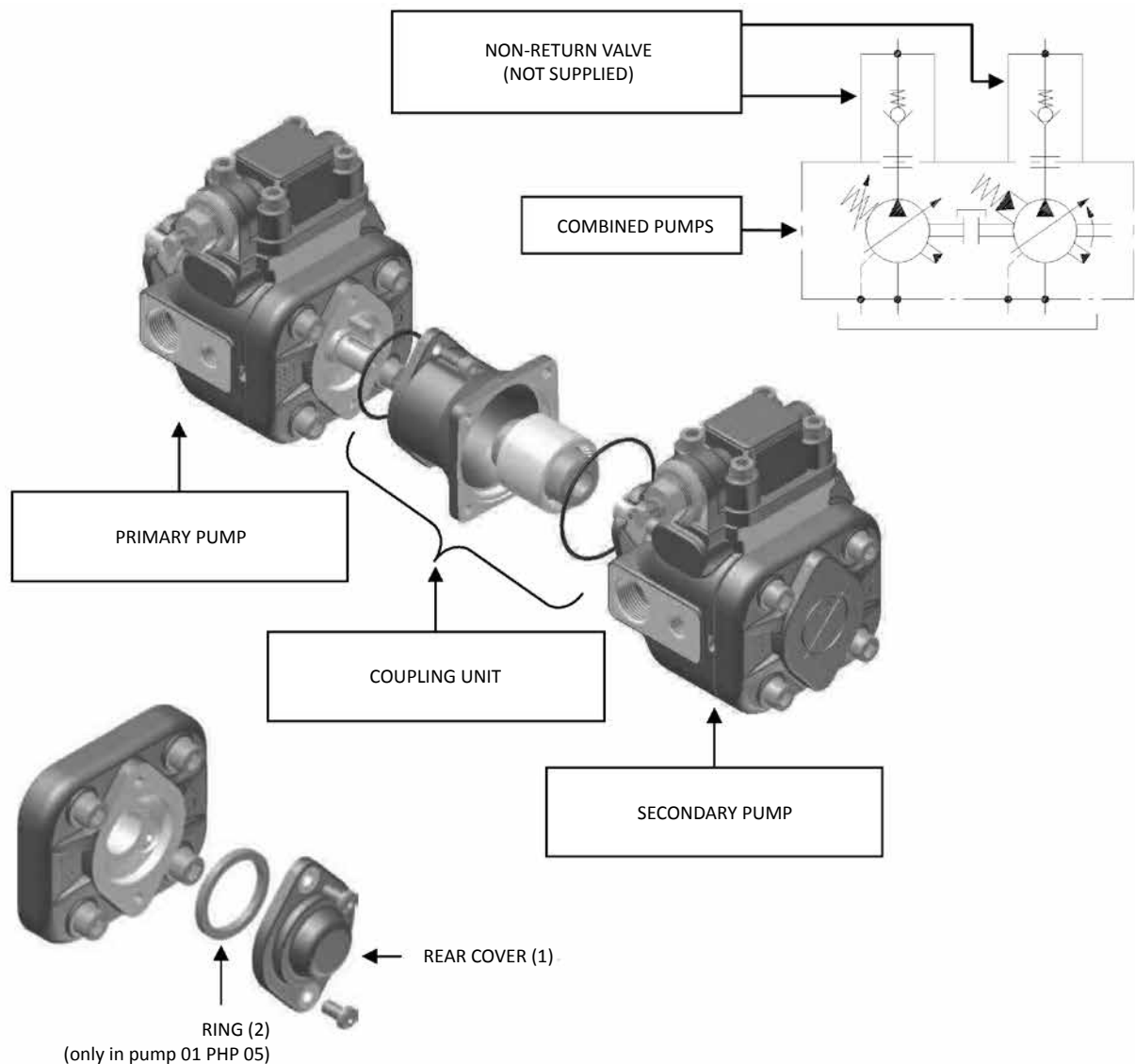

Combined pumps should be mounted in decreasing order of absorbed power, paying attention to the maximum acceptable torques (see diagram on the following page).

The ordering code for a combined pump should be specified according to coupling sequence (primary pump code + coupling unit code + secondary pump code).



- The sum of individual torques of all pumps in the complete pump combination must not exceed the maximum permissible torque value applicable to the primary pump shaft (T_{max} see page 4).
- Secondary pump torque (or sum of torques for more than one secondary pump) must not exceed the coupling unit maximum thru drive torque (T_a , see table below).

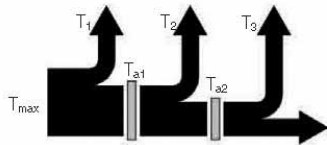

$$\begin{cases} T_1 + T_2 + T_3 < T_{max} \\ T_2 + T_3 < T_{a1} \\ T_3 < T_{a2} \end{cases}$$

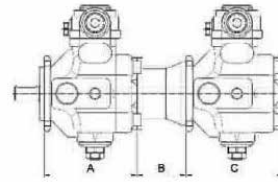

PRIMARY PUMP		SECONDARY PUMP		COUPLING UNIT		
Pump type	A	Pump type	C	Code	B	Maximum thru drive torque T_a
01 PHP 05 16 F..A	139	01 PLP 05 16 F	107	3000010200	73	55 Nm
		01 PLP 05 16 FGR2	107	3000011200	72	
		01 PHP 05 16 F	145	3000010200	73	
		01 PHP 05 16 FGR2	145	3000011200	72	
		SAE "A"	(*)	3100000100	88.5	
		GEAR PUMP 1P	(**)	3000011000	64	
		GEAR PUMP 1	(**)	3000011100	64	
GEAR PUMP 2	(**)	3000011200	72			
01 PHP 1 (20-25-32) F..A	163	01 PLP 05 16 F	107	3000010200	73	
		01 PLP 05 16 FGR2	107	3000011200	72	
		01 PHP 05 16 F	145	3000010200	73	
		01 PHP 05 16 FGR2	145	3000011200	72	
		SAE "A"	(*)	3100000100	88.5	
		GEAR PUMP 1P	(**)	3000011000	64	
		GEAR PUMP 1	(**)	3000011100	64	
		GEAR PUMP 2	(**)	3000011200	72	
		01 PLP 1 (20-25-32) F	166	3000010100	75	
01 PHP 1 (20-25-32)F	166	3000010100	75			
01 PHP 2 (40-50-63) F..A 01 PHP 3 (80-100-120) F..A	199.5	GEAR PUMP 1P	(**)	3000022000	90	
		GEAR PUMP 1	(**)	3000022100	90	
		GEAR PUMP 2	(**)	3000022200	90	
	237	GEAR PUMP 3	(**)	3000022300	91	
		01 PLP 05 16 F	107	3000020400	85	
		01 PLP 05 16 FGR2	107	3000022200	90	
		01 PHP 05 16 F	145	3000020400	85	
		01 PHP 05 16 FGR2	145	3000022200	90	
		01 PLP 1 (20-25-32) F	166	3000020100	87	
		01 PHP 1 (20-25-32)F	166	3000020100	87	
		01 PLP 2 (40-50-63)F	202.5	3000020200	102	
		01 PHP 2 (40-50-63)F	202.5	3000020200	102	
		SAE "A"	(*)	3100000200	100.5	
SAE "B"	(*)	3100000300	126.5			
01 PHP 3 (80-100-120) F..A	237	01 PHP 3 (80-100-120) F	240	3000020300	117	180 Nm
		01 PLP 3 (80-100-120) F	240	3000020300	117	

(*) For the secondary pump flange dimensions please see page 26-27.
To find out the secondary pump axial dimension please see the manufacturer's catalogue.

(**) For the secondary gear pump flange dimensions please see page 26-27.
In order find out the secondary gear pump axial dimension please see the manufacturer's catalogue.

For other coupling unit types, please contact Berarma Technical-Sales Service.

SAE FLANGE DIMENSIONS FOR BERARMA COUPLING KIT

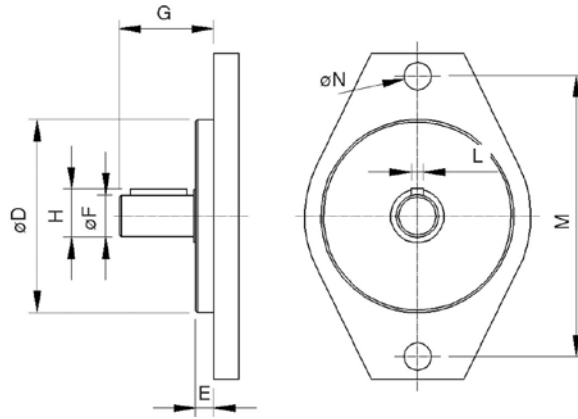

Secondary pump	Secondary pump with SAE flange should conform to the dimensions below								
	Ø D	E	Ø F	G		H	L	M	Ø N
				min	max				
SAE "A"	Ø82.5	7	Ø19.05	32	59	21.1	4.8	106.4	11.1
SAE "B"	Ø101.6	9.5	Ø22.2	41	71	25.1	6.375	146	14.3
						25.5	4.8		

GEAR PUMP FLANGE DIMENSIONS FOR BERARMA COUPLING KIT

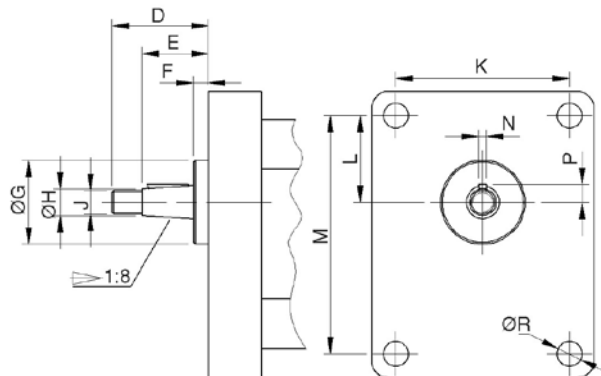

Secondary pump	Secondary gear pumps should conform to the dimensions below											
	D	E	F	Ø G	Ø H	J	K	L	M	N	P	Ø R
gear pump 1P	29	20	4	25.4	8	M7	52.4	26.2	71.9	2.4	5.3	7.5
gear pump 1	35	23.5	5.5	30	12	M10x1	56	24.5	73	3	7.9	6.5
gear pump 2	40	28	5	36.5	14.7	M12x1.5	71.5	32.5	96	4 (*)	9.7	8.5
gear pump 3	47	33	5	50.8	19	M14x1.5	98.5	43	128	4	12.2	11