

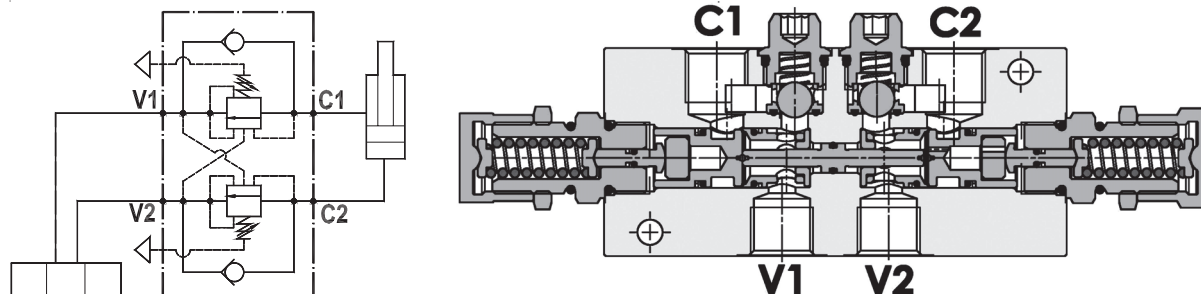

**Valvola overcenter doppia parzialmente bilanciata, montaggio in linea, serie E**  
**Partially balanced dual overcenter valve, line mounted, E series**

Rev.01-2010/02

**SPECIFICHE TECNICHE**

**Materiali:** corpo in alluminio. I componenti interni sono in acciaio trattato termicamente.

**Portata max.:** 70 l/min

**Taratura max.:** 350 bar

**Rapporto di pilotaggio:** 1 : 3.2 (a richiesta 1 : 8.2)

**Regolazione pressione:** mediante vite

**Campo di regolazione pressione:** vedere pag.02

**Peso:** 1,400 Kg

**TECHNICAL SPECIFICATIONS**

**Materials:** body is in aluminium alloy. Internal parts are in hardened steel.

**Rated flow:** up to 70 l/min

**Max. setting:** 350 bar

**Pilot ratio:** 1 : 3.2 (standard), 1 : 8.2 on request

**Adjustment means:** leakproof screw adjustment

**Adjustable pressure range:** see page 02

**Weight:** 1,400 Kg

**DIAGRAMMA PERDITE DI CARICO - PRESSURE DROP CURVES**

Viscosità olio 24 mm<sup>2</sup>/sec. (3,5 °E)  
 Temperatura 50 °C

Oil viscosity 24 mm<sup>2</sup>/sec. (3,5 °E)  
 Temperature 50 °C

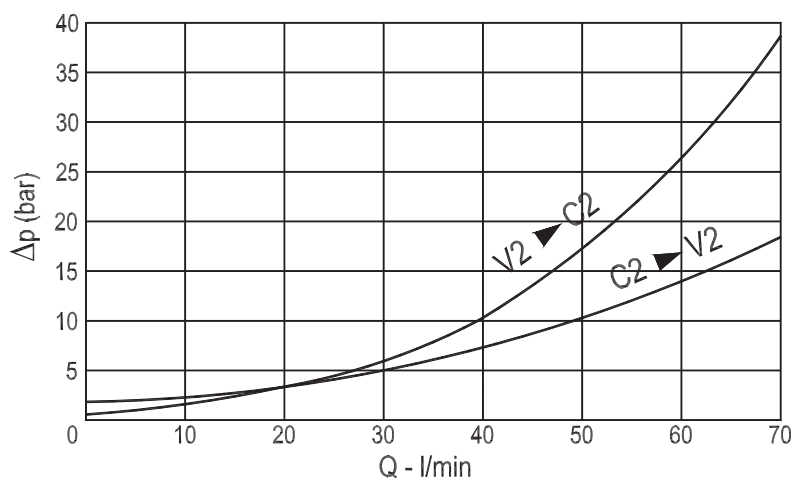

**Valvola overcenter doppia parzialmente bilanciata, montaggio in linea, serie E**  
**Partially balanced dual overcenter valve, line mounted, E series**

Rev.01-2010/02

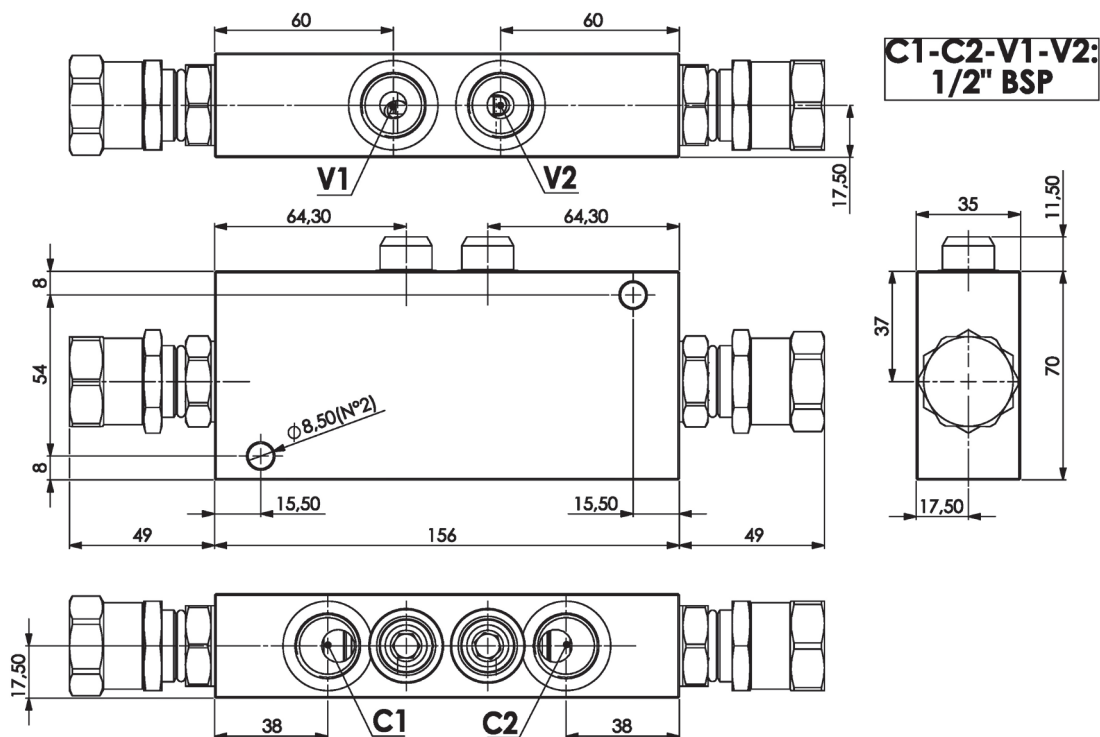

MOLLE - SPRINGS				*
Codice Code	Rapp. pil. Pilot ratio	Campo taratura min.-max. bar Adjustable pressure range bar	Increment. press. bar/giro vite Pressure increase bar/turn	Taratura standard bar Standard setting bar
20	1 : 3.2	60 - 210	56	200
20	1 : 8.2	60 - 210	56	200
35	1 : 3.2	120 - 350	90	350
35	1 : 8.2	120 - 350	90	350

**ESEMPIO DI ORDINAZIONE - ORDERING CODE EXAMPLE**

**F P O E B** **7 0** **D** **1 / 2** **L** **A** **2 0** **B**

\* "20" / "35":  
 Campi di taratura pressione - Adjustable pressure

Rapporto di pilotaggio  
 Pilot ratio  
 Omettere se standard \*  
 Omit if standard  
 B = 1 : 8.2